

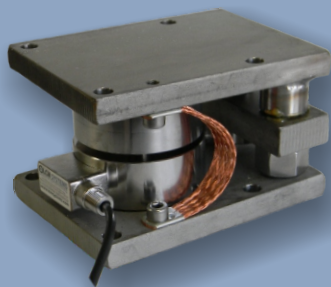

TYPE: CDIT-3-WMOUNT



CDIT-3-WMOUNT Weighing Assembly

Description

The CDIT-3-WMOUNT is a complete weighing assembly for use with the CDIT-2 and CDIT-3 range of load cells (see separate data sheet). The weighing assembly facilitates easy mounting for the engineer on site, and incorporates a number of key features that allows the best installed accuracy to be achieved. These include an anti-lift off mechanism, compensation for thermal expansion and for off-axis loading.

Manufactured from stainless steel, the CDIT-3-WMOUNT is available in three sizes (assembly instructions are shown on the reverse of this data sheet). The unit is equipped with self load alignment to mitigate against positioning errors and deformation of structures.

Features

- Stainless steel construction
- Aids installation
- Ensures best installation accuracy is achieved
- Incorporates a safety retainer to prevent accidental vessel lifting or sliding
- Available in three sizes
- Suitable for use with the CDIT-2 and CDIT-3 load cell series

Dimensions

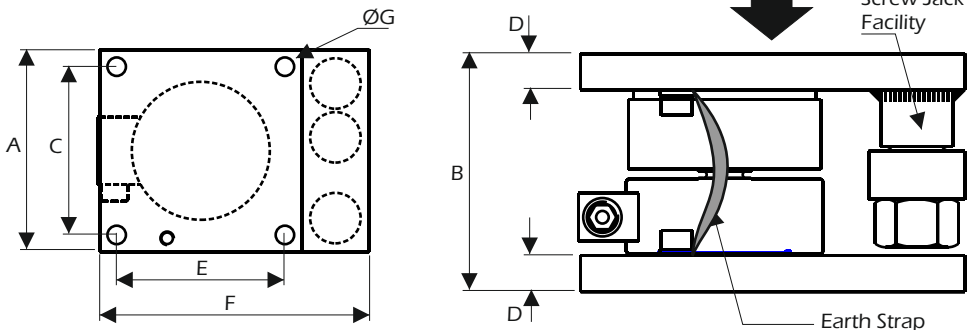

Rating	A	B	C	D	E	F	ØG	Weight
100kg to 10te (Size 1)	120	100	100	15	100	160	8 x Ø11	7
20te to 30te (Size 2)	200	112	160	15	110	200	8 x Ø18	14
50te to 100te (Size 3)	270	135	214	15	174	300	28 x Ø25	31

Typical Applications

- Vessel weighing
- Silo weighing
- Process weighing & control
- Tank weighing

Installation Examples

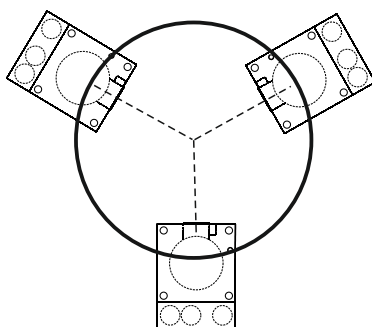

Circular system with three supporting points

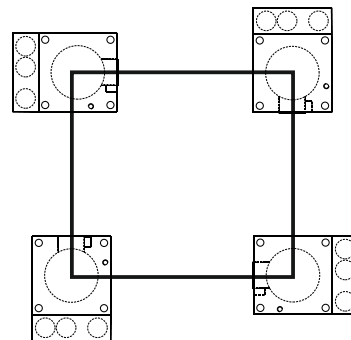

Square system with four supporting points

	100kg to 10te Size 1	20te to 30te Size 2	50te to 100te Size 3
Nominal load (tonnes)	10	30	100
Maximum permissible horizontal force (kN)	25	50	120
Maximum permissible lifting force (kN)	40	80	210

CDIT-3-WMOUNT Weighing Assembly

Assembly Instructions

- Fix the CDIT-3-WMOUNT loading plate (1) to the structure or to the floor, checking that the floor is flat and even. If not, use separate levelling plates.
- Place the system to be weighed on the upper plates (2), taking care that the load cells are not overloaded.
- Adjust and fix the upper plate (2), ensuring that it is parallel and in axis with the lower plate.
- Check that the safety retainer (3) is centred inside the hole, ensuring that it is free to move, especially during weighing.

Load Cell Replacement

- Lift the weighing units upper plate (2) by unscrewing the two lifting jacks (4), ensuring that the upper plate is jacked evenly.
- Replace the load cell
- Screw the two jacks (4) to lower the upper plate evenly back onto the load cells

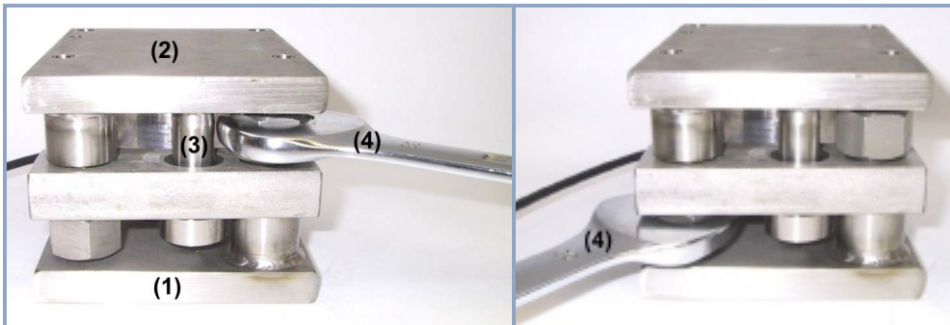

Warning:

- Take care to avoid accidental overloading of the load cells whilst assembling the unit.
- Make sure that current does not pass through the load cell.
- During welding operations, place the mass pliers in the upper part of the weighing unit.
- We recommend that all relevant safety laws are assessed and strictly observed.
- The installer should perform a thorough environmental risk analysis (seismic zones, wind etc) and must also make provisions for a suitable anti-rollover device.

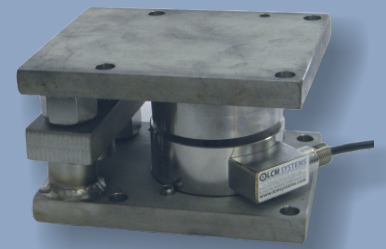

SCIENCE GATE
Your Automation Partner

SCIGATE AUTOMATION (S) PTE LTD

No 1 Bukit Batok Street 22 #01-01 Singapore 659592
Tel: (65) 6561 0488 Fax: (65) 6561 0588
Email: sales@scigate.com.sg Web: https://scigate.com.sg/
Business Hours: Monday - Friday 8:30AM - 6:15PM

www.lcmsystems.com

LCM Systems Ltd

Unit 15, Newport Business Park, Barry Way
Newport, Isle of Wight PO30 5GY UK
Tel: +44 (0)1983 249264
sales@lcmsystems.com
www.lcmsystems.com

LCM Systems (România)

Strada Ștefan Cel Mare 26a,
Tunari, cod.077180, Ilfov, România
Tel: +40 (0)77 4641899
ro@lcmsystems.com
www.lcmsystems.ro

Due to continual product development, LCM Systems Ltd reserves the right to alter product specifications without prior notice.

Issue No. 3

Issue date: 03/02/2021
APPROVED
(unapproved if printed)